INTERMOT DUAL DISPLACEMENT MOTORS

IAC SERIES

TECHNICAL CATALOGUE

INDEX

GENERAL INFORMATION	<i>Pag.</i>	2
ORDERING INSTRUCTIONS	"	3
MOTOR TECHNICAL DATA	"	4
HYDRAULIC FLUIDS RECOMMENDATIONS	"	7
INSTRUCTIONS AND ADVICES	"	8
DRAIN RECOMMENDATIONS	"	12
SHAFT SEAL FEATURES	"	13
FORMULAS	"	14
CONVERSIONS	"	14
IAC H1 SERIES	"	15 - 22
IAC H3 SERIES	"	23 - 30
IAC H4 SERIES	"	31 - 41
IAC H5 SERIES	"	43 - 50
IAC H6 SERIES	"	51 - 58
IAC H7 SERIES	"	59 - 63
FLOW DISTRIBUTORS	"	65 67
ACCESSORIES	"	69 - 88

GENERAL INFORMATIONS

INTERMOT produces RADIAL PISTON HYDRAULIC MOTORS since 1985: our yearly production is more than 13.000 units which we sell all over the world through our agents and authorized sellers. Our motor range varies from 20cc to 8500cc displacement and it is completed by two-speed motors and special motors created in cooperation with our clients for different applications such as : underwater, high & low speed and wheel motors and with the possibility to assemble valves, brakes or gear reductions. You can directly contact our Technical Department which will give you all the necessary support to find the right solutions to your problems.

INTERMOT is a flexible work reality and manages deliveries also within the same day of order; we produce motors exactly interchangeable with our competitors, always ready on stock which our customers particularly appreciate.

Pressure commands for displacement change

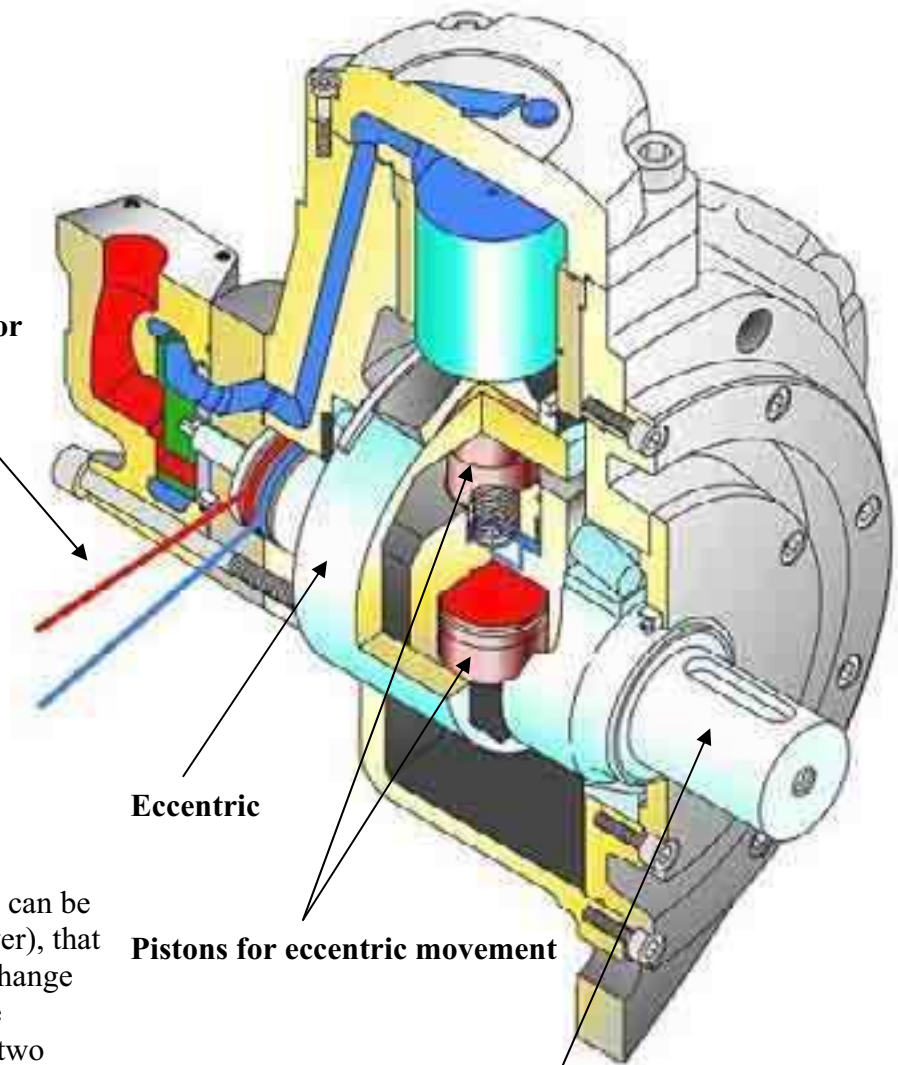

Working explanation

There is an external valve (that can be activated by a solenoid or a lever), that is responsible of the pressure change in the pressure commands. The pressure commands act on the two pistons inside the eccentric; the pistons move and therefore pull the eccentric, that cause the pistons stroke variation and, therefore the displacement change. In this manner we can have two displacement in the same motor.

Eccentric

Pistons for eccentric movement

Motor shaft

ORDERING INSTRUCTIONS

IAC SERIES

	<input type="text" value="IAC --"/>	<input type="text" value="/-"/>	<input type="text" value="H1"/>	<input type="text" value="A -"/>	<input type="text" value="D --"/>	<input type="text" value="---"/>	<input type="text" value="---"/>	<input type="text" value="SV"/>	<input type="text" value="SB -"/>	<input type="text" value="---"/>	<input type="text" value="---"/>	<input type="text" value="---"/>	<input type="text" value="---"/>
Motor model													
Motor interchangeability													
	<input type="text" value="/C"/>	<input type="text" value="/B30"/>	<input type="text" value="/BH"/>										
	<input type="text" value="/S"/>	<input type="text" value="/B45"/>											
Housing	<input type="text" value="H1"/>												
	<input type="text" value="H3"/>												
	<input type="text" value="H4"/>												
	<input type="text" value="H5"/>												
	<input type="text" value="H6"/>												
	<input type="text" value="H7"/>												
Shaft													
	<input type="text" value="A0"/>	splined shaft	<input type="text" value="A3"/>	female shaft									
	<input type="text" value="A1"/>	splined shaft											
	<input type="text" value="A2"/>	parallel shaft											
Distributor													
	<input type="text" value="D40"/>	(1" BSP)											
	<input type="text" value="D47"/>	(SAE 3000 1")											
	<input type="text" value="D75"/>	(SAE 3000 1" 1/2)											
	<input type="text" value="D90"/>	(SAE 6000 1" 1/2)											
Tachometer (optional)													
	<input type="text" value="TA"/>												
	<input type="text" value="TB"/>												
	<input type="text" value="EST"/>												
	<input type="text" value="EST.30"/>												
	<input type="text" value="J"/>	TACHOMETER PREDISPOSITION											
Cetop 3 fitting (optional)													
	<input type="text" value="C3"/>	(Cetop 3 fitting)											
	<input type="text" value="C3-12"/>	(Cetop 3 fitting, with 12V DC valve included)											
	<input type="text" value="C3-24"/>	(Cetop 3 fitting, with 24V DC valve included)											
Shuttle valve (optional)													
	<input type="text" value="SV"/>												
Spline billet (optional)													
	<input type="text" value="SB3"/>	<input type="text" value="SB7"/>	<input type="text" value="SB10"/>	<input type="text" value="SB16"/>									
	<input type="text" value="SB6"/>	<input type="text" value="SB9"/>	<input type="text" value="SB14"/>										
Valves (optional)													
	<input type="text" value="RVDA"/>	<input type="text" value="OVDA"/>	<input type="text" value="RVDAP"/>	(see valve section for details and complete ordination code)									
	<input type="text" value="OVSA"/>	<input type="text" value="ORVSA"/>											
Special features (optional)													
	<input type="text" value="01"/>	(Viton seals)											
	<input type="text" value="02"/>	(Oxynit treatment on the external motor surface)											
	<input type="text" value="03"/>	(Nitemper treatment on cylinder bores)											
Conversion flange (optional) (see conversion flanges section)													
	<input type="text" value="FL2"/>	<input type="text" value="FL6"/>											
	<input type="text" value="FL4"/>	<input type="text" value="FL7"/>											
	<input type="text" value="FL5"/>												
Displacements													
	<input type="text" value="MAX-MIN"/>	(MAXIMUM AND MINIMUM DISPLACEMENT OF MOTOR)											

MOTOR TECHNICAL DATA

IAC 195 H1

Displacement [cc/Rev]	195	175	150	125	100	95	75	69
Specific theoretical torque [Nm/bar]	3.1	2.8	2.4	2	1.6	1.5	1.2	1.1
Continuous maximum speed [rpm]	750	750	750	775	775	775	800	850
Minimum speed [rpm]	3	3	3	4	4	4	5	5
Mechanical efficiency [%]	89.5	89.2	89	88.5	88	87.8	87	85.5
Starting mechanical efficiency [%]	84.5	84.2	85	84.5	84	83	81	78
Continuous maximum power [kW]	36	34	32	30	28	28	26	24
Intermittent maximum power [kW]	45	42.5	40	37.5	35	35	32.5	30
Continuous maximum pressure [bar]	250	250	250	250	250	250	250	250
Intermittent maximum pressure [bar]	275	275	275	275	275	275	275	275
Peak pressure [bar]	350	350	350	350	350	350	350	350
Recommended flushing flow [l/min]	8	8	8	8	8	8	8	8

IAC 250 H1

Displacement [cc/Rev]	257	232	195	175	150	125	100	95
Specific theoretical torque [Nm/bar]	4.1	3.7	3.1	2.8	2.4	2	1.6	1.5
Continuous maximum speed [rpm]	700	700	750	750	750	775	775	775
Minimum speed [rpm]	3	3	3	3	3	4	4	5
Mechanical efficiency [%]	88.5	88.2	88	87.5	87	86.8	86	84.5
Starting mechanical efficiency [%]	83.5	83.2	84	83.5	83	82	80	77
Continuous maximum power [kW]	38	37	36	34	32	30	28	28
Intermittent maximum power [kW]	47.5	46	45	42.5	40	37.5	35	35
Continuous maximum pressure [bar]	250	250	250	250	250	250	250	250
Intermittent maximum pressure [bar]	275	275	275	275	275	275	275	275
Peak pressure [bar]	350	350	350	350	350	350	350	350
Recommended flushing flow [l/min]	10	10	10	10	10	10	10	10

IAC 500 H3

Displacement [cc/Rev]	492	442	393	344	292	255	197	147	98
Specific theoretical torque [Nm/bar]	7.8	7	6.3	5.5	4.7	4.1	3.1	2.3	1.6
Continuous maximum speed [rpm]	450	505	520	545	580	595	600	600	600
Minimum speed [rpm]	2	2	2	2	2	3	3	3	4
Mechanical efficiency [%]	87.5	86	85	83.6	82.4	82	80	78	73.4
Starting mechanical efficiency [%]	82.5	81	80	77.2	74.3	69.6	62.1	52	30
Continuous maximum power [kW]	61	60	57	50	44	36	26	20	9
Intermittent maximum power [kW]	66	75	71	62.5	55	45	21	25	11
Continuous maximum pressure [bar]	250	250	250	250	250	250	250	250	250
Intermittent maximum pressure [bar]	275	275	275	275	275	275	275	275	275
Peak pressure [bar]	350	350	350	350	350	350	350	350	350
Recommended flushing flow [l/min]	10	10	10	10	10	10	10	10	10

IAC 800 H4

Displacement [cc/Rev]	792	660	575	493	410	328	273	245	165
Specific theoretical torque [Nm/bar]	12.6	10.5	9.2	7.8	6.5	5.2	4.3	3.9	2.6
Continuous maximum speed [rpm]	450	540	600	600	600	600	600	600	600
Minimum speed [rpm]	2	2	2	2	2	2	2	3	3
Mechanical efficiency [%]	90.8	90.4	88.5	88	87.4	84.5	82.4	82	60.2
Starting mechanical efficiency [%]	84.8	84.4	82.6	79	75	70.2	68.3	60.8	43.3
Continuous maximum power [kW]	100	90	80	68	53	43	38	30	15
Intermittent maximum power [kW]	120	108	96	82	64	52	46	36	18
Continuous maximum pressure [bar]	250	250	250	250	250	250	250	250	250
Intermittent maximum pressure [bar]	275	275	275	275	275	275	275	275	275
Peak pressure [bar]	350	350	350	350	350	350	350	350	350
Recommended flushing flow [l/min]	10	10	10	10	10	10	10	10	10

IAC 1400 H5

Displacement [cc/Rev]	1600	1499	1393	1313	1235	1150	1070	980	900	820
Specific theoretical torque [Nm/bar]	25,5	23,9	22,2	20,9	19,7	18,3	17	15,6	14,3	13
Continuous maximum speed [rpm]	370	400	410	435	440	460	480	490	495	520
Minimum speed [rpm]	1	1	1	1	1	1	1	1	1	2
Mechanical efficiency [%]	94,2	94	93,9	93,7	93,5	93,4	93,2	93	92,6	92,3
Starting mechanical efficiency [%]	88,2	88	86,5	85,3	85,1	82,6	81,3	79,8	77,9	76
Continuous maximum power [kW]	139	138	135	128	127	124	119	115	110	105
Intermittent maximum power [kW]	171	170	166	158	157	153	147	142	136	130
Continuous maximum pressure [bar]	250	250	250	250	250	250	250	250	250	250
Intermittent maximum pressure [bar]	275	275	275	275	275	275	275	275	275	275
Peak pressure [bar]	350	350	350	350	350	350	350	350	350	350
Recommended flushing flow [l/min]	12	12	12	12	12	12	12	12	12	12

Displacement [cc/Rev]	737	655	574	492	410	328	246	164	82
Specific theoretical torque [Nm/bar]	11,7	10,4	9,1	7,8	6,5	5,2	3,9	2,6	1.3
Continuous maximum speed [rpm]	545	600	600	600	600	600	600	600	1000
Minimum speed [rpm]	2	2	2	2	2	3	3	3	4
Mechanical efficiency [%]	91	89,3	87	83	81,7	75,5	65,7	60,5	0
Starting mechanical efficiency [%]	72,9	83,2	65	59,2	51	39	18	0	0
Continuous maximum power [kW]	98	91	78	65	53	39	28	14	0
Intermittent maximum power [kW]	121	112	96	80	65	48	35	17	0
Continuous maximum pressure [bar]	250	250	250	250	250	250	250	250	17
Intermittent maximum pressure [bar]	275	275	275	275	275	275	275	275	17
Peak pressure [bar]	350	350	350	350	350	350	350	350	17
Recommended flushing flow [l/min]	12	12	12	12	12	12	12	12	15

IAC 3000 H6

Displacement [cc/Rev]	3085	2950	2790	2620	2460	2290	2130	1970	1800
Specific theoretical torque [Nm/bar]	49,1	47	44,4	41,7	39,2	36,5	33,9	31,4	28,7
Continuous maximum speed [rpm]	235	240	245	250	250	265	285	305	340
Minimum speed [rpm]	1	1	1	1	1	1	1	1	1
Mechanical efficiency [%]	95	94,5	94,2	94	93,7	93,5	92,8	92,3	92
Starting mechanical efficiency [%]	86	85,4	84,4	83,6	82,4	82	80,2	78	76
Continuous maximum power [kW]	175	175	175	165	155	150	140	130	122
Intermittent maximum power [kW]	196	196	196	185	174	168	157	146	137
Continuous maximum pressure [bar]	250	250	250	250	250	250	250	250	250
Intermittent maximum pressure [bar]	275	275	275	275	275	275	275	275	275
Peak pressure [bar]	350	350	350	350	350	350	350	350	350
Recommended flushing flow [l/min]	12	12	12	12	12	12	12	12	12

Displacement [cc/Rev]	1640	1470	1310	1150	980	820	670	490	330
Specific theoretical torque [Nm/bar]	26,1	23,4	20,9	18,3	15,6	13,1	10,7	7,8	5,2
Continuous maximum speed [rpm]	370	400	425	455	490	520	600	600	600
Minimum speed [rpm]	1	1	1	1	1	2	2	2	3
Mechanical efficiency [%]	91	90,5	88	86,2	82,3	81,7	78	76	73,2
Starting mechanical efficiency [%]	73	70	66,4	62	55,4	46,3	33	0	0
Continuous maximum power [kW]	115	106	100	89	81	73	62	49	25
Intermittent maximum power [kW]	129	119	112	100	91	82	70	55	35
Continuous maximum pressure [bar]	250	250	250	250	250	250	250	250	250
Intermittent maximum pressure [bar]	275	275	275	275	275	275	275	275	275
Peak pressure [bar]	350	350	350	350	350	350	350	350	350
Recommended flushing flow [l/min]	12	12	12	12	12	12	12	12	12

IAC 4600 H7

Displacement [cc/Rev]	4617	4177	3650	3280	2950	2620	2290	1970	1640
Specific theoretical torque [Nm/bar]	73,5	66,5	58,1	52,2	47	41,7	36,5	31,4	26,1
Continuous maximum speed [rpm]	150	158	168	175	210	235	275	305	380
Minimum speed [rpm]	1	1	1	1	1	1	1	1	1
Mechanical efficiency [%]	95,3	95,1	94,5	94,4	93,3	92,4	91,5	90,1	86,5
Starting mechanical efficiency [%]	85,1	84	83,3	82,5	81,2	80,1	78	75,2	72,4
Continuous maximum power [kW]	190	180	165	150	140	129	115	104	88
Intermittent maximum power [kW]	213	202	185	169	157	145	129	122	110
Continuous maximum pressure [bar]	250	250	250	250	250	250	250	250	250
Intermittent maximum pressure [bar]	275	275	275	275	275	275	275	275	275
Peak pressure [bar]	350	350	350	350	350	350	350	350	350
Recommended flushing flow [l/min]	12	12	12	12	12	12	12	12	12

Displacement [cc/Rev]	1310	980	655	492	328	164	82	0
Specific theoretical torque [Nm/bar]	20,9	15,6	10,4	7,8	5,2	2,6	0	0
Continuous maximum speed [rpm]	435	460	495	520	550	1000	1000	1000
Minimum speed [rpm]	1	1	2	2	3	3	4	0
Mechanical efficiency [%]	83	78,4	76,2	66	46,4	0	0	0
Starting mechanical efficiency [%]	67,2	58	41	23,7	0	0	0	0
Continuous maximum power [kW]	73	56	38	27	15	0	0	0
Intermittent maximum power [kW]	96	80	56	39	20	0	0	0
Continuous maximum pressure [bar]	250	250	250	250	250	250	17	17
Intermittent maximum pressure [bar]	275	275	275	275	275	275	17	17
Peak pressure [bar]	350	350	350	350	350	350	17	17
Recommended flushing flow [l/min]	12	12	12	12	12	12	15	15

IAC 5400 H7

Displacement [cc/Rev]	5326	5080	4915	4588	4097	3650	3280	2950	2620	2295
Specific theoretical torque [Nm/bar]	84,8	80,9	78,2	73	65,2	58,1	52,2	47	41,7	36,5
Continuous maximum speed [rpm]	130	135	140	150	160	170	190	215	230	280
Minimum speed [rpm]	1	1	1	1	1	1	1	1	1	1
Mechanical efficiency [%]	95,2	95	95	95	95	94,4	94,3	93,2	92	91,5
Starting mechanical efficiency [%]	86	85,8	85,8	85,4	85,2	83	82,2	82	79,8	77,7
Continuous maximum power [kW]	190	190	190	190	178	162	152	140	130	120
Intermittent maximum power [kW]	216	216	216	216	200	182	170	160	145	135
Continuous maximum pressure [bar]	250	250	250	250	250	250	250	250	250	250
Intermittent maximum pressure [bar]	275	275	275	275	275	275	275	275	275	275
Peak pressure [bar]	350	350	350	350	350	350	350	350	350	350
Recommended flushing flow [l/min]	12	12	12	12	12	12	12	12	12	12

Displacement [cc/Rev]	1970	1640	1560	1311	980	655	492	328	164	0
Specific theoretical torque [Nm/bar]	31,4	26,1	24,8	20,9	15,6	10,4	7,8	5,2	2,6	0
Continuous maximum speed [rpm]	335	375	410	445	470	500	520	550	1000	1000
Minimum speed [rpm]	1	1	1	1	1	2	2	3	3	0
Mechanical efficiency [%]	90	86	84,5	82,3	78,3	76,2	66,2	46,5	0	0
Starting mechanical efficiency [%]	75,3	72,1	71,3	67	58	41	24	0	0	0
Continuous maximum power [kW]	105	90	85	75	58	40	26	15	0	0
Intermittent maximum power [kW]	120	110	102	98	82	56	40	20	0	0
Continuous maximum pressure [bar]	250	250	250	250	250	250	250	250	17	17
Intermittent maximum pressure [bar]	275	275	275	275	275	275	275	275	17	17
Peak pressure [bar]	350	350	350	350	350	350	350	350	17	17
Recommended flushing flow [l/min]	12	12	12	12	12	12	12	12	15	15

HYDRAULIC FLUIDS RECOMMENDATIONS

HYDRAULIC FLUIDS

We recommend the use of hydraulic oils with anti-wear additives (ISO HM or HV) and minimum viscosity index of 95. Once normal working temperature is reached, oil viscosity must be at least 44 cSt, preferably in the range from 50 to 80 cSt.

Hydraulic oils meeting Denison MF-O, Vickers M-2952-S I - 286-S performance requirements and DIN 51524 specifications, are preferred.

Pay particular attention if you use HE type oils (ecological fluid) because they can influence the motor seals compatibility, the motor performance and life. Please ask us for advice in case of HE type oils usage.

Mineral hydraulic oils are divided into four main types, designated by the International Standards Organisation (ISO) as HH, HL, HM and HV. We advise to use only products with HM or HV specifications.

HM type

These are the most widely employed hydraulic oils. They include small quantities of anti-wear additives to provide significant improvement in wear reduction. "Superior" quality HM type oils can be used for all equipment, with the added assurance that they will be suitable for the highest temperature.

HV type

HV hydraulic oils show minimal change in viscosity with temperature variations.

OIL VISCOSITY RECOMMENDATION

Room temperature HM type ISO-VG

- -20°C / 0°C BP ENERGOL HLP - HM 22
- -15°C / +5°C BP ENERGOL HLP - HM 32
- -8°C / +15°C BP BNERGOL HLP - HM 46
- 0°C / +22°C BP ENERGOL HLP - HM 68
- +8°C / +30°C BP ENERGOL HLP - HM100
- -20°C / +5°C BP BARTRAN HV 32
- -15°C / +22°C BP BARTRAN HV 46
- 0°C / +30°C BP BARTRAN HV 68

Our motors have been designed to work also with:

- oils type ATF (Automatic Transmission Fluid)
- oils with viscosity SAE 10W - 20 - 30
- multigrade motor oils SAE 10 W/40 or 15 W/40
- universal oils

During cold start-up, avoid high-speed operation until the system is warmed up to provide adequate lubrication.

Continuous working temperature must not exceed 70°C. Every 5-8°C of increase from the optimum working temperature, the hydraulic fluid life decrease of about 40-50% (see OXIDATION). Therefore the motor life will be affected by consequence.

FIRE RESISTANT OIL LIMITATIONS

	Max cont. pressure	Max int. pressure	Max speed
HFA, 5-95% oil-water	103	138	50%
HFB, 60-40% oil-water	138	172	100%
HFC, water-glycol	103	138	50%
HFD, ester phosphate	250	293	100%

FILTRATION

Hydraulic systems oil must always be filtered.

The choice of filtration grade derives from needs of service life and money spent. In order to obtain stated service life it is important to follow our recommendations concerning filtration grade.

When choosing the filter it is important to consider the amount of dirt particles that filter can absorb and still operate satisfactorily. For that reason we recommend filters showing when you need to substitute filtering cartridge.

According to NAS 1628, we recommend:

- maximum permissible oil contamination degree according to NAS 1628 class 9 (using filters with minimum efficiency $\beta_{10}=100$), for normal service life;
- maximum permissible oil contamination degree according to NAS 1628 class 8 (using filters with minimum efficiency $\beta_5=100$) for closed circuit applications and long service life;

OXIDATION

Hydraulic oil oxidizes with time of use and temperature. Oxidation causes changes in colour and smell, acidity increase or sludge formation in the tank. Oxidation rate increases rapidly at surface temperatures above 60°C, in these situations oil should be checked more often. Every 5-8°C of increase from the optimum working temperature, the hydraulic fluid life decrease of about 40-50%.

The oxidation process increases the acidity of the fluid; the acidity is stated in terms of the "neutralization number". Oxidation is usually slow at the beginning and then it increases rapidly.

A sharp increase (by a factor of 2 to 3) in neutralization number between inspections shows that oil has oxidized too much and should be replaced immediately.

WATER CONTENT

Oil contamination by water can be detected by sampling from the bottom of the tank. Most hydraulic oils repel the water, which then collects at the bottom of the tank. This water must be drained off at regular intervals. Certain types of transmission oils and engine oils emulsify the water; this can be detected by coatings on filter cartridges or a change in the colour of the oil. In such cases, obtain your oil supplier advice.

DEGREE OF CONTAMINATION

Heavy contamination of the oil causes wear rising in hydraulic system components. Contamination causes must be immediately investigated and remedied.

ANALYSIS

In optimum operating conditions, we recommend to perform an oil analysis 6 months. The analysis should cover viscosity, oxidation, water content, additives and contamination. Most oil suppliers are equipped to analyze oil state and to recommend appropriate action. Oil must be immediately replaced if the analysis shows that it is exhausted.

INSTRUCTIONS AND ADVICES

INSTALLATION

Hoses and piping must be clean and free from contamination. The motor must be fitted on a flat, robust surface using the right bolts (see the following table for your reference).

Motor	Bolts	Bolts preload
IAC 250/S H1	M12	70÷85 Nm
IAC 250/BH H1	M10	40÷50 Nm
IAC 500 H3	M14	110÷135 Nm
IAC 500/B30 H3	M16	128÷212 Nm
IAC 800/B45 H4	M16	128÷212 Nm
IAC 800/C H4	M12	70÷85 Nm
IAC 800 H4	M16	128÷212 Nm
IAC 1400 H5	M20	332÷413 Nm
IAC 1400/C H5	M14	110÷135 Nm
IAC 3000 H6	M20	332÷413 Nm
IAC 3000/C H6	M18	235÷290 Nm
IAC 4600 H7	M18	235÷290 Nm
IAC 5400 H7	M18	235÷290 Nm

The clearance between the motor flange diameter and the mounting diameter must not exceed a maximum value that can be set approximatively to 0.15 mm. In special working conditions, in which the motor is operating with frequent reversing, high speed running, vibrations, and shock loadings, high tensile stress fixing bolts must be used, whereas one must be included as fitting bolt.

In the case in which the motor is coupled in a rigid way to a shaft having independent bearings, the two shafts must be aligned in the way to have a maximum error of about 0.1 mm.

- Motor can be mounted in any position (refer to drain recommendations to obtain more detailed guidelines)
- In run-away conditions you must use counterbalance valves
- Consult factory for intermittent applications

Splined adaptors (sleeves) are available upon request.

INSTALLATION CIRCUIT

The choice of open or closed loop circuit will be determined by the application.

Open loop circuits are cheaper and simpler to install.

Closed loop circuit is a superior circuit and usually takes up less space. It also offers better control features. In case of using closed loop circuit please contact Intermot technical department.

START UP

Motor case and pistons must be completely filled with oil before starting. Do not load motor to maximum working pressure. Increase load gradually at start-up. When it is possible, a short "running in" period of 30 minutes is highly recommended (keeping the motor in maximum displacement).

CASE DRAIN – CASE PRESSURE

Referring to drain pipes, the recommended minimum size for pipe lengths up to about 5 m is 12 mm as internal diameter. If the drain pipes are longer, the internal bore drain pipe diameter must be increased by consequence. Keep the pipe length always at the minimum possible value, connecting the case drain directly to tank.

The case drain port on the motor must be located on the highest point of the installation to ensure that the motor will

always be full of oil. Intermot IAC motors are equipped with high pressure shaft seal: refer to the "shaft seal features" page for the maximum continuous case pressure estimation. Intermot performed internal tests that shows that the case pressure can be up to 10 bar continuous and 15 bar intermittent without causing damage to the shaft seal. Especially in the case in which the drain line is quite long, a relief valve is recommended to prevent the shaft seal damage.

IMPORTANT

When the motor is installed vertically with shaft pointing upwards, consult our Technical Department. If the motor is connected to high inertial loads, the hydraulic system must be designed to prevent peaks of pressure and cavitation.

TEMPERATURE

Refer to hydraulic fluid recommendations.

VISCOSITY

Refer to hydraulic fluid recommendations.

HIGH PRESSURE APPLICATIONS

In case of high pressure applications, a Nitemper treatment on motor body or in cylinders it is suggested to increase wear and tear resistance.

BACK PRESSURE

Don't exceed 70 bar back pressure. A small return line back pressure between 2 and 5 bar is recommended in some cases to attenuate the liquid born noise level. In addition the back pressure counteract the centrifugal forces in the motor. Please notice that the back pressure reduces the effective motor output torque.

BOOST PRESSURE

When the motor runs at a speed that can cause pumping effects, a positive pressure it is needed at the motor ports. The minimum required pressure at the motor ports can be estimated basing on different parameters, using the following formula:

$$p = 1 + p_c + C_H n^2 V^2$$

Where p is the boost pressure, p_c the case pressure, n the rotation speed, V the motor displacement, and C_H is a constant, depending by the motor serie.

Motor	C_H
IAC 250 H1	$0,25 \cdot 10^{-9}$
IAC 500 H3	$0,25 \cdot 10^{-9}$
IAC 800 H4	$0,5 \cdot 10^{-10}$
IAC 1400 H5	$0,5 \cdot 10^{-10}$
IAC 3000 H6	$0,4 \cdot 10^{-10}$
IAC 4600/5400 H7	$0,25 \cdot 10^{-10}$

MINIMUM SPEED

The minimum acceptable speed depends by different variables, like load inertia, motor displacement, system leakages, etc... For indicative values refer to motor technical data. When it is possible, always start the motor in high displacement, to avoid start-up problems.

DISPLACEMENT CHANGE

The displacement change can be performed in different ways. The user can use an internal or external pilot. In addition Intermot can supply a Cetop 3 fitting with or without Cetop 3 displacement change valve (with electric or hydraulic control). To perform the displacement change, the pilot pressure must be at least 2/3 of the motor working pressure. If the motor working pressure is less than 3,5 bar, the pilot pressure must be at least 3,5 bar. Please note that in freewheeling operation it is necessary supply the displacement control mechanism with an external supply pressure/flow source. This external supply source will assure that the motor displacement during the freewheeling operation remains fixed at the minimum value, avoiding IAC motor damage.

The oil flow rate required to perform the displacement change can be estimated in function of many different parameters; the most important factor that determinate the required flow rate is the motor case internal leakage. The flow rate that is shown in the next table must be considered as an indicative value that depends by many system parameters and working conditions.

Motor	Required flow rate	Displacement change delay
IAC 250 H1	8 l/min	0,2 s
IAC 500 H3	12 l/min	0,2 s
IAC 800 H4	15 l/min	0,25 s
IAC 1400 H5	30 l/min	0,25 s
IAC 3000 H6	15 l/min	0,5 s
IAC 4600 H7	20 l/min	1 s
IAC 5400 H7	20 l/min	1 s

The system components (pumps, motors...) present tear and wear phenomenons that are clearly variables during the system life, so the required flow rate is variable during the motor life, this variation is very difficult to estimate: for this reason the values reported must be considered as approximated and indicative values.

DISPLACEMENT CHANGE HYDRAULIC CIRCUIT

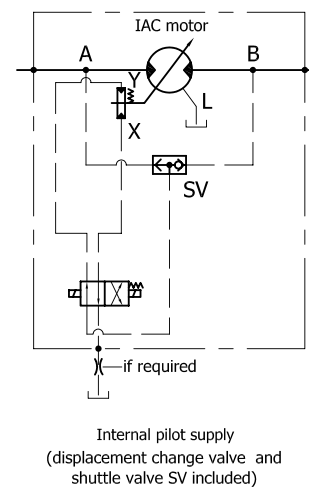
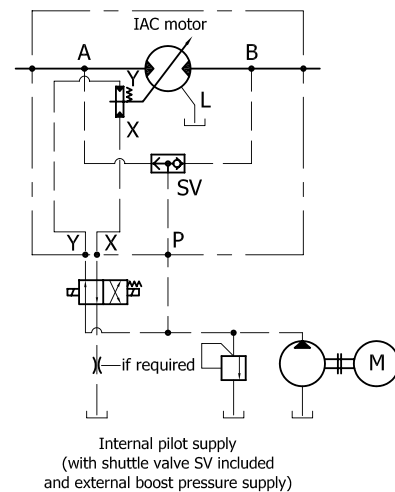
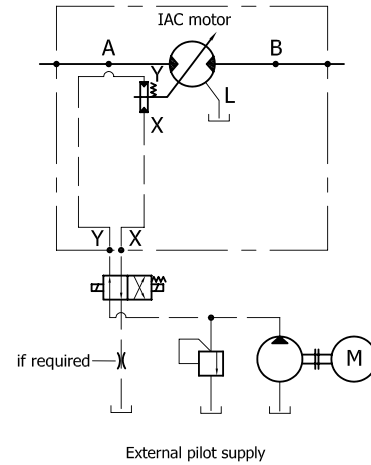
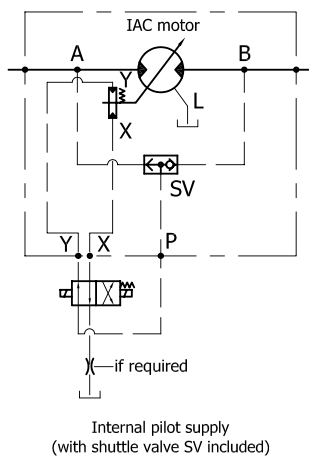

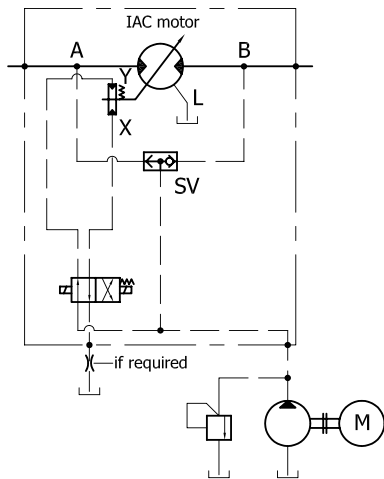

Internal pilot supply
(displacement change valve and shuttle valve SV included with external boost supply)

SMALL DISPLACEMENT/FREEWHEELING OPERATION

Selecting a zero displacement IAC motor, the motor can run without load at high speed, resulting in a minimum motor torque requirement. The motor ports must be connected together (refer to the following diagram) and must be supplied with an external pressure/flow source.

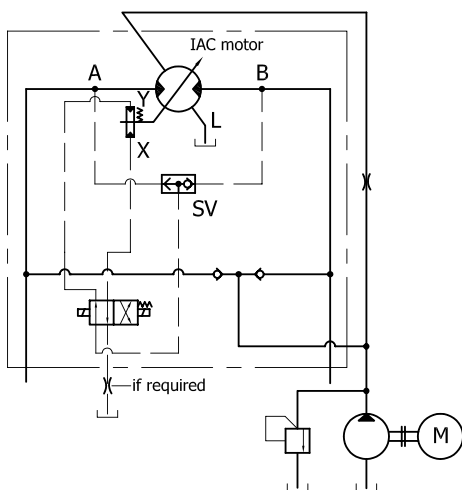

Freewheeling circuit

The maximum working pressure shown in the motor technical data for the zero displacement code are relatives to a 1000 rpm shaft speed. If the output shaft speed is less than 1000 rpm the maximum working pressure can be slightly increased.

Consult Intermot technical department to obtain more details. For output shaft speed higher than 1000 rpm the

application duty cycle must be considered by Intermot.

When the motor is running at high speed, a minimum pressure must exist at the motor ports (see boost pressure paragraph), but in all cases this pressure must not exceed the maximum working pressure reported in the zero displacement code motor technical data. A crankcase flushing flow is highly recommended in freewheeling operation, to control and reduce the motor temperature rise during the freewheeling. If the motor running speed is between 1000 and 1500 rpm, a 15 l/min (indicative value) flushing flow is compulsory.

BEARINGS

The bearing life depends by different factors, like bearing type, motor speed, working pressure, external loads, duty cycle, fluid viscosity, cleanliness, type and temperature.

Lifetime is measured by L_{10} which is called "theoretic lifetime". It represents the number of cycles that 90% of identical bearings can effort at the same load without showing wear and tear. It is calculated by the following equation:

$$L_{10} = \left(\frac{C}{P} \right)^p$$

where: C = theoretical dynamic coefficient (depending on the bearing size)

P = radial load

p = exponent (p=3 for ball bearings, p=10/3 for roller bearings)

When you work at constant speed, you can calculate the lifetime in hours with the following equation:

$$L_{10h} = \frac{10^6 \cdot L_{10}}{60 \cdot \text{rpm}} = \frac{10^6}{60 \cdot \text{rpm}} \left(\frac{C}{P} \right)^p \text{ [h]}$$

When you don't have only radial or axial loads, you have to calculate an equivalent load:

$$P = X \cdot F_R + Y \cdot F_A$$

Where

F_R = radial load,

X = radial coefficient,

F_A = axial load,

Y = axial coefficient

While F_R and F_A come from working conditions (i.e. torque), X

and Y depend on the type of bearing and on the ratio $\frac{F_A}{F_R}$.

L_{10} is a theoretical value, that must be corrected to take into account other important parameters, that in most applications are very difficult to estimate.

To help you in the expected lifetime calculation, Intermot provides you with an EXCEL calculation sheet. The expected lifetime that Intermot supply you by the Excel sheet is calculated supposing that the oil viscosity is equal to the recommended value in function of bearing medium diameter and rotational speed (refer to the following diagram). The reference medium bearing diameter is shown in the next table.

Motor	Bearing medium diameter
IAC 250 H1	60 mm
IAC 500 H3	95 mm
IAC 800 H4	95 mm
IAC 1400 H5	125 mm
IAC 3000 H6	150 mm
IAC 4600 H7	150 mm
IAC 5400 H7	150 mm

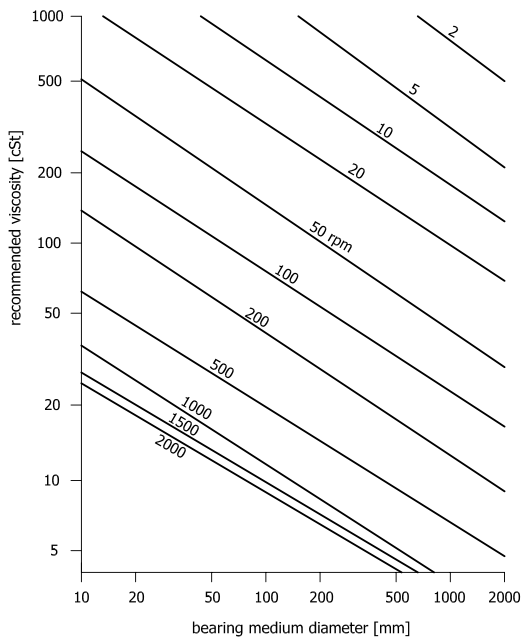

Starting from the L_{10} or L_{10hr} that are theoretical values, you can obtain a more accurate bearing lifetime estimation, supposing that the oil has a very low contamination level (refer to hydraulic fluid recommendation), using the following formula:

$$L_{na} = a_v L_{10} / f_s$$

a_v is the viscosity factor, and can be estimated referring to the following diagram, whereas f_s is the service factor, that is dependent by the duty cycle (refer to the service factor table).

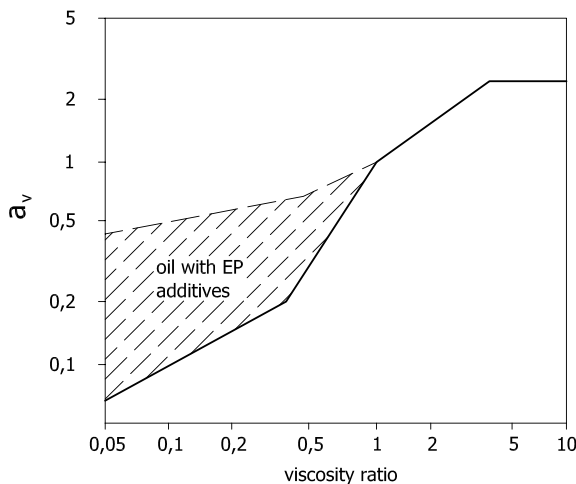

Continuous working duty cycle	Service factor (f_s)
< 6 h	1.2
< 12 h	1.4
< 24 h	2.8

The viscosity ratio is the ratio between the viscosity and the recommended viscosity. In this way, using the Excel sheet, that is provided by Intermot and calculating the corrected lifetime L_{na} , you can easily estimate the bearing lifetime: you only need to choose the motor model, put speed, pressure and loads.

For further information or to have the calculation sheet, please contact our technical department.

FLUSHING

Cooling flow is necessary to assure the minimum oil viscosity and depends on motor displacement. On radial piston hydraulic motors with high volumetric efficiency, and therefore Intermot IAC series, there can be a phenomenon of oil-overheating in the body motor. In fixed applications, for example, where the motor is running constantly for 8 or more hours a day (like injection machines for plastic materials, press, bending machines, etc.) high volumetric efficiency can create temperature increasing in motor body. In this case temperature increasing is to be avoided with the use of flushing. Flushing consists in carrying fresh oil (taken from hydraulic circuit) in the body motor. Oil is usually taken from return line to avoid any loss of efficiency. In this way, all internal parts of the motor are protected with this lubrication and cooled with fresh oil, so that total efficiency is optimised.

INTERCHANGEABILITY; COMPARATIVE CHART

We can provide many IAC motor types interchangeable with Intermot competitors like Staffa Kawasaki, Parker Calzoni, Dinamic Oil and SAI.

Intermot motor code	Competitor motor code
IAC 250/S H1	SAI GM1, SAI M1
IAC 250/BH H1	Dinamic Oil BH
IAC 500/B30 H3	Staffa HMC30 (S shaft)
IAC 800/B45 H4 A1	Staffa HMC45 (S shaft)
IAC 800/B45 H4 A11	Staffa HMC45 (Z shaft)
IAC 800/B45 H4 A2	Staffa HMC45 (P shaft)
IAC 800/C H4	Calzoni MRD700, MRDE800 (N1 shaft)
IAC 1400 H5 A1	Staffa HMC80 (S shaft)
IAC 1400 H5 A2	Staffa HMC80 (P shaft)
IAC 1400/C H5 A0	Calzoni MRD1100, MRDE1400 (N1 shaft)
IAC 1400/C H5 A3	Calzoni MRD1100, MRDE1400 (F1 shaft)
IAC 3000 H6 A1	Staffa HMC200 (S shaft)
IAC 3000 H6 A2	Staffa HMC200 (P shaft)
IAC 3000/C H6 A0	Calzoni MRD2800, MRDE3100 (N1 shaft)
IAC 4600 H7 A1	Staffa HMC270 (S shaft)
IAC 5400 H7 A1	Staffa HMC325 (S shaft)

DRAIN RECOMMENDATIONS

Motor axis horizontal

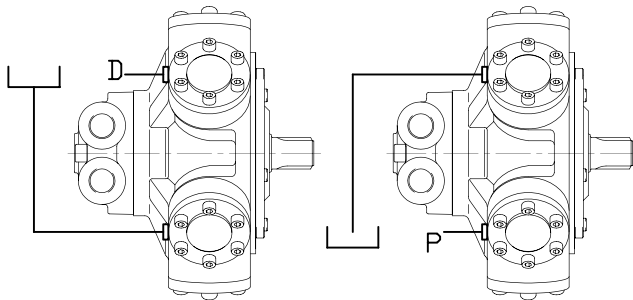

Axis vertical, shaft up

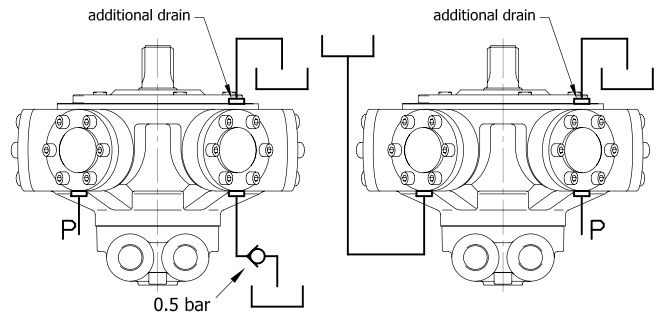

Axis vertical, shaft down

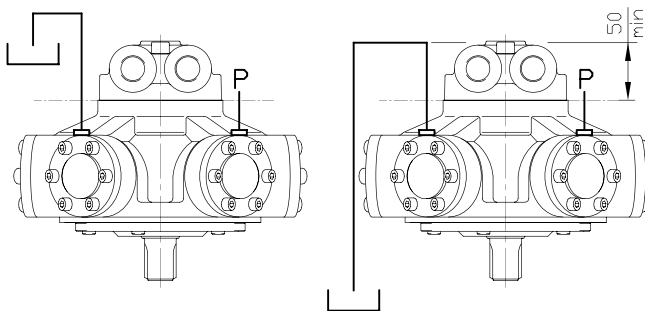

P=plug D=drain

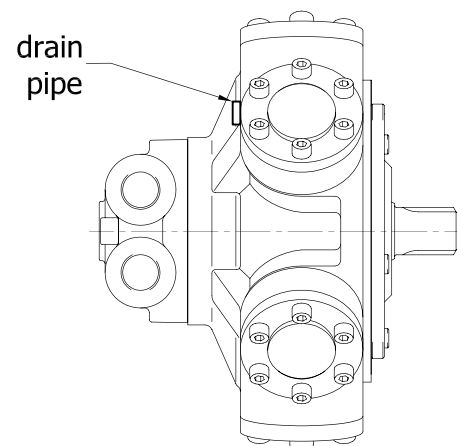

IMPORTANT

For all motors IAC series, it is necessary TO FILL the motor case with hydraulic fluid, through the drain pipe, before start-up.

DISTRIBUTORS PRESSURE – FLOW

		D40/D47 (IAC H1, H3, H4)	D75 (IAM H5)	D90 (IAC H6, H7)
Pressure bar	Continuous	250	250	250
	Max	500	500	500
Flow L/min	Continuous	200	500	600
	Max	400	1000	1200

SHAFT SEAL FEATURES

Type: BABSL
 Form: AS DIN 3760
 Material: SIMRIT® 72 NBR 902
 SIMRIT® 75 FKM 595

1. Features

SIMMERRING® radial shaft seal with rubber covered O.D., short, flexibility suspended, spring loaded sealing lip and additional dust lip: see Part B/ SIMMERRING®, sections 1.1 and 2.

2. Material

Sealing lip and O.D.:

- Acrylonitrile-butadiene rubber with 72 Shore A hardness (designation: SIMRIT® 72 NBR 902)
- Fluoro rubber with 75 Shore A hardness (designation: SIMRIT® 75 FKM 595)

Metal insert:

- Plain steel DIN 1624

Spring:

- Spring steel DIN 17223

3. Application

For sealing pressurised media without additional backup ring, e. g. for rotational pressure sealing in hydraulic pumps, hydraulic motors, hydrodynamic clutches. Rubber covered O.D. assures sealing in the housing bore even in case of considerable surface roughness, thermal expansion or split housing.

Particularly suitable for sealing low viscosity and gaseous media.

Where high thermal stability and chemical resistance are required, SIMRIT® 75 FKM 595 material should be used. Additional dust lip to avoid the entry of light and medium dust and dirt.

4. Operating conditions

See Part B/ SIMMERRING®, sections 2. 4.

Media: mineral oils, synthetic oils
 Temperature: -40°C to +100°C (SIMRIT® 72 NBR 902)
 -40°C to +160°C (SIMRIT® 75 FKM 595)

Surface speed: up to 5 m/s

Working pressure: see diagram 1

Maximum permitted values, depending on other operating conditions.

5. Housing and Machining Criteria

See Part B/ SIMMERRING®, sections 2.

Shaft:	Tolerance:	ISO h11
	Concentricity:	IT 8
	Roughness:	Ra=0.2-0.8 µm Rz=1-4 µm Rmax=6 µm
	Hardness:	45-60 HRC
	Roughness:	non oriented; preferably by plunge grinding
Housing:	Tolerance:	ISO H8
	Roughness:	Rmax<25 µm

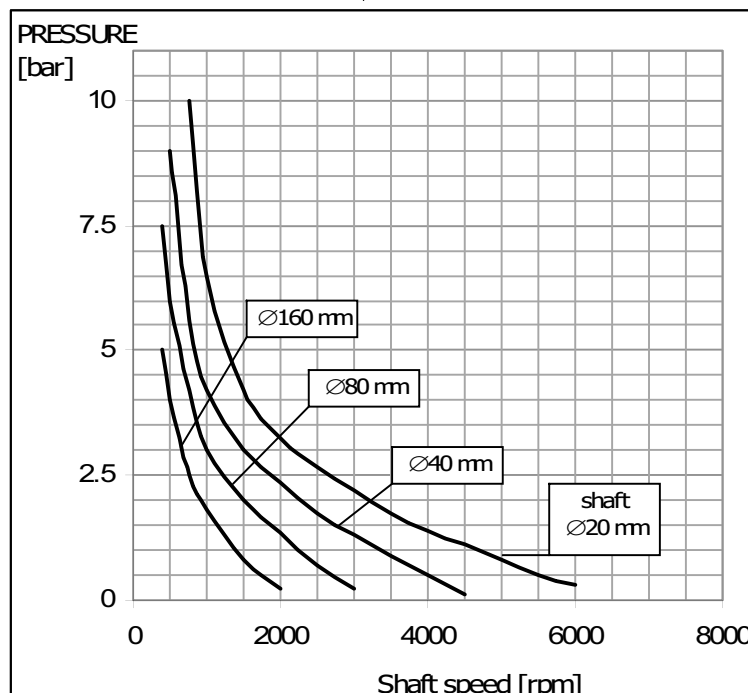

Diagram 1: Pressure Loading Limits

FORMULAS

• TORQUE (1)	Torque = (specific torque) · (pressure)
• TORQUE (2)	$\text{Torque [Nm]} = \frac{\text{displacement [cc/rev]} \cdot \text{pressure [bar]}}{62.8}$
• POWER (1)	$\text{Power [kW]} = \frac{\text{Torque [Nm]} \cdot \text{speed [rpm]}}{9549}$
• POWER (2)	$\text{Power [CV]} = \frac{\text{Torque [Nm]} \cdot \text{speed [rpm]}}{7023}$
• SPEED	$\text{speed [rpm]} = \frac{\text{flow rate [l/min]} \cdot 1000}{\text{displacement [cc/rev]}}$
• REQUIRED MOTOR DISPLACEMENT	$\text{displacement [cc/rev]} = \frac{\text{max required torque [Nm]} \cdot 62.8}{\text{max pressure [bar]}}$
• REQUIRED PUMP FLOW RATE	$\text{flow [l/min]} = \frac{\text{displacement [cc/rev]} \cdot \text{max speed [rpm]}}{1000}$

CONVERSIONS

LENGTH	1 m = 39.3701 in	1 lbf = 0.4536 kgf
	= 3.2808 ft	= 4.448 N
	= 1.0936 yd	
	= 1000 mm	PRESSURE
1 in = 0.0833 ft		1 bar = 14.223 psi
= 25.4 mm		= 0.99 atm
1 ft = 0.3048 m		= 1.02 ata
= 0.3333 yd		= 100000 Pa
= 12 in		= 100 kPa
1 yd = 0.9144 m		= 0.1 MPa
= 3 ft		1 psi = 0.0703 bar
= 36 in		FLOW
1 km = 1000 m		1 l/min = 0.264 gpm
= 1093.6 yd		= 1000 cc/min
= 0.6214 mile		1 gpm = 3.785 l/min
1 mile = 1.609 km		= 3785 cc/min
= 1760 yd		1 m ³ /s = 60000 l/min
		= 15852 gpm
MASS	1 kg = 2.2046 lb	VOLUME
1 lb = 0.4536 kg		1 m ³ = 1000 l
SPEED	1 m/s = 3.6 km/h	1 l = 61,023 in ³
	= 2.237 mph	= 0,264 galUS
	= 3.2808 ft/s	1 in ³ = 0,01639 l
1 km/h = 0.2778 m/s		= 16,39 cm ³
= 0.6214 mph		= 0,004326 galUS
= 0.9113 ft/s		1 galUS = 3,7879 l
1 mph = 1.609 km/h		= 231,15 in ³
= 0.447 m/s		POWER
= 1.467 ft/s		1 kW = 1.341 HP
1 ft/s = 0.3048 m/s		= 1.3596 CV
= 1.0973 km/h		1 HP = 0.7457 Kw
= 0.6818 mph		= 1.0139 CV
FORCE	1 N = 0.102 kgf	TORQUE
= 0.2248 lbf		1 Nm = 0.102 kgm
1 kgf = 2.205 lbf		= 0.7376 lbf ft
= 9.806 N		1 kgm = 9.806 Nm
		= 7.2325 lbf ft
		1 lbf ft = 0.1383 kgm
		= 1.3558 Nm